

Crimped bellow 8" x 1

DBS081002

INDUSTRY

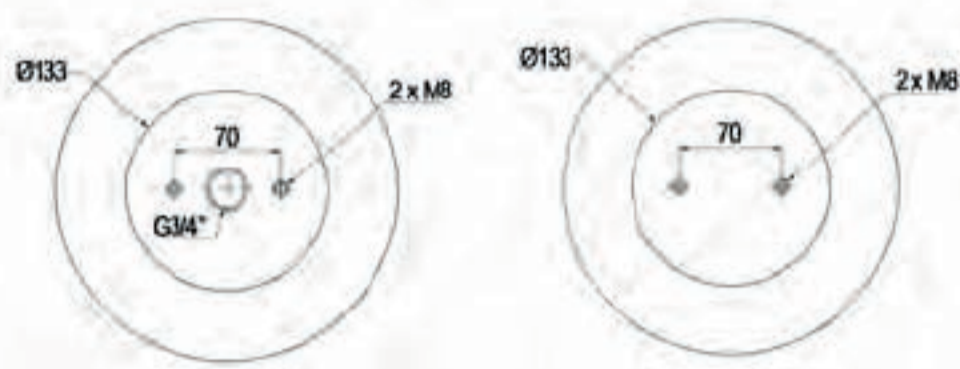
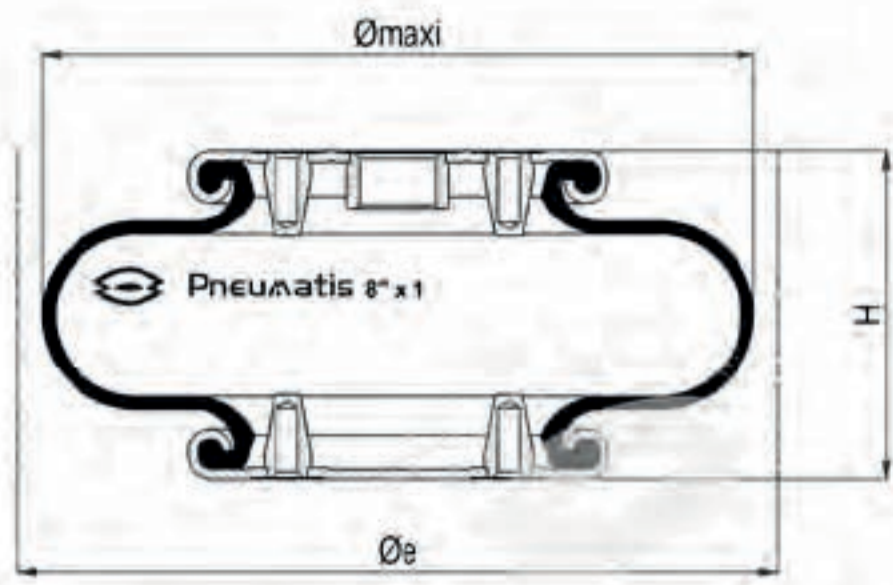

Technical characteristics

Maximum pressure	8 bar
Burst pressure	32 bar
Maximum angular capacity	10°
Maximum out of alignment	10 mm

Static diameter	225 mm
Maximum diameter	225 mm
Minimum overall diameter (Øe)	240 mm
Minimum height	55 mm
Static height (H)	105 mm
Maximum height	150 mm
Maximum recommended height	140 mm
Total stroke	95 mm
Effective area at static height	200 cm ²
Stiffness at 4 bar	20,49 daN/mm
Natural frequency at 4 bar	2,52 Hz
Weight	1,8 kg

Dynamic characteristics at H = 115 mm*

Pressure	2 bar	4 bar	6 bar
Load (daN)	350	715	1080
Volume (dm ³)	2,24	2,30	2,36
Stiffness (daN/mm)	10,35	18,57	26,53
Natural frequency (Hz)	2,72	2,54	2,47
Isolation rate at 10Hz %	92	93,1	93,1

* Recommended height for better isolation

Volume in cm³

Load in daN

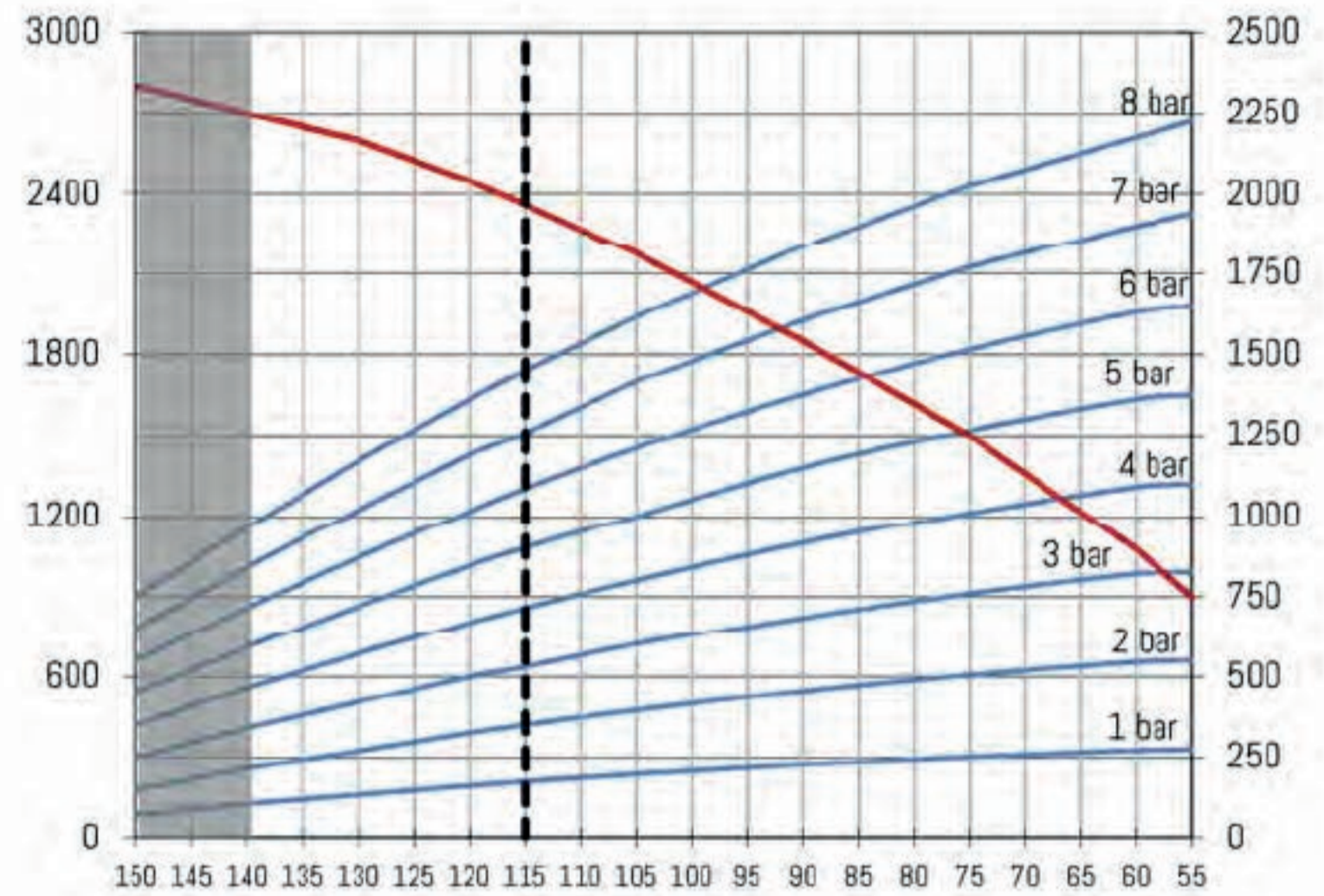

— Volume
- - - H Isolation

Temperatures

Standard	-40°C (-50°C static)	+70°C (+90°C static)
----------	----------------------	----------------------

References

DBS081002 Crimped bellow 1 convolute 8" x 1 air inlet G^{3/4} centered

Characteristics in static condition (daN)

Height	2 bar	3 bar	4 bar	5 bar	6 bar	7 bar	8 bar	Vol 6 bar
55 mm	550	825	1100	1375	1650	1940	2225	900 cm ³
60 mm	545	820	1090	1360	1630	1900	2175	1075 cm ³
75 mm	505	760	1010	1265	1515	1770	2025	1500 cm ³
90 mm	455	685	915	1150	1375	1605	1835	1850 cm ³
105 mm	395	600	800	1000	1210	1415	1615	2175 cm ³
115 mm	350	530	715	885	1085	1255	1450	2360 cm ³
120 mm	325	500	670	845	1015	1190	1360	2450 cm ³
130 mm	270	420	570	720	870	1020	1170	2600 cm ³
140 mm	215	340	465	590	715	840	965	2700 cm ³
150 mm	150	250	350	450	550	650	750	2800 cm ³

Mounting instructions

Fastening torque M8 x 1,25 : 25 Nm

Indicative value of force to reach the minimum height at atmospheric pressure is 6 daN.