

Bellow 16" x 2 Stainless steel

DB16226

INDUSTRY

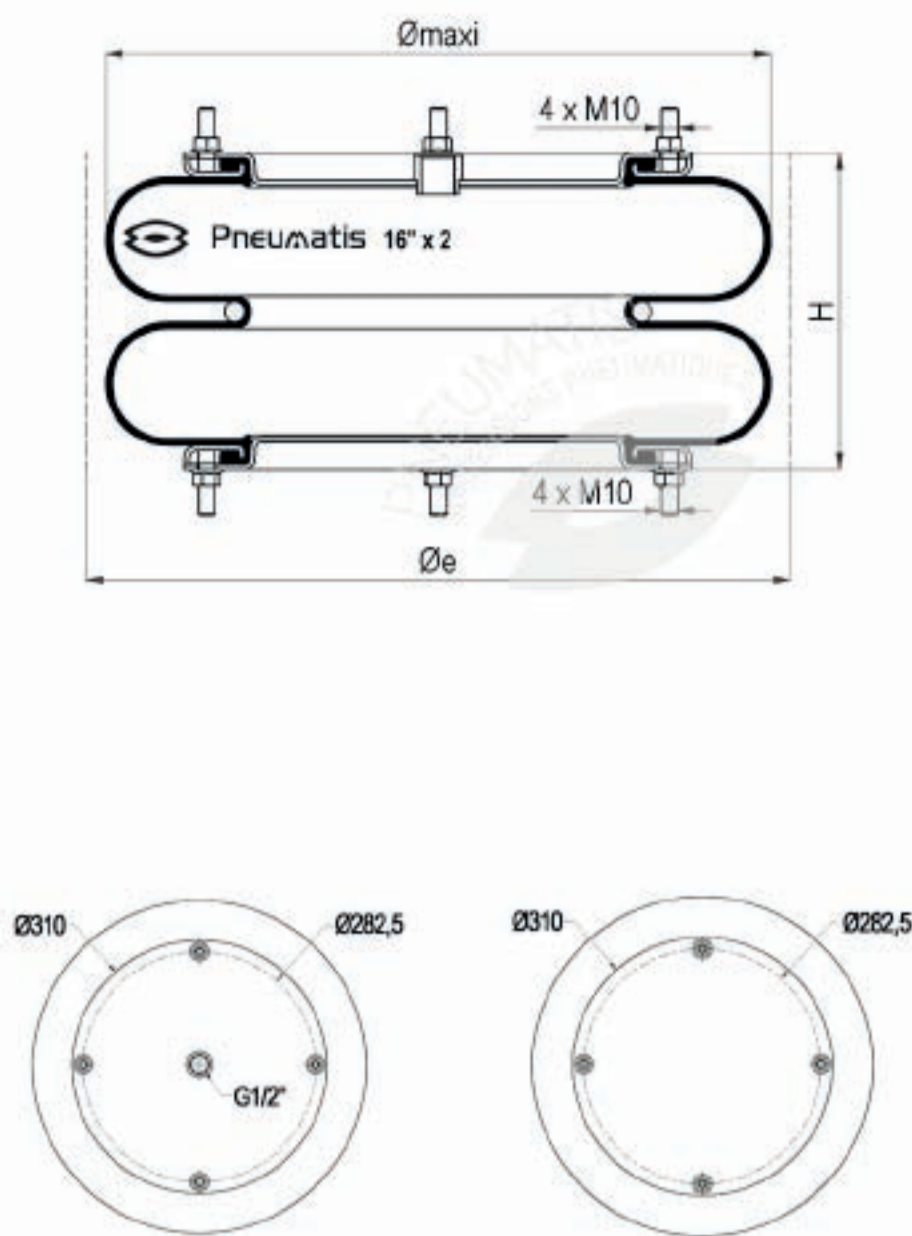

Technical characteristics

Maximum pressure	8 bar
Burst pressure	24 bar
Maximum angular capacity	15°
Maximum out of alignment	10 mm

Static diameter	406 mm
Maximum diameter	440 mm
Minimum overall diameter (Øe)	460 mm
Minimum height	75 mm
Static height (H)	200 mm
Maximum height	325 mm
Maximum recommended height	300 mm
Total stroke	250 mm
Effective area at static height	870 cm ²
Stiffness at 4 bar	63 daN/mm
Natural frequency at 4 bar	1,71 Hz
Weight	9,7 kg

Dynamic characteristics at H = 290mm*

Pressure	2 bar	4 bar	6 bar
Load (daN)	1270	2575	3865
Volume (dm ³)	24,25	24,85	25,46
Stiffness (daN/mm)	126	228	323
Natural frequency (Hz)	1,57	1,48	1,44
Isolation rate at 10Hz %	97,5%	97,8%	97,9%

* Recommended height for better isolation

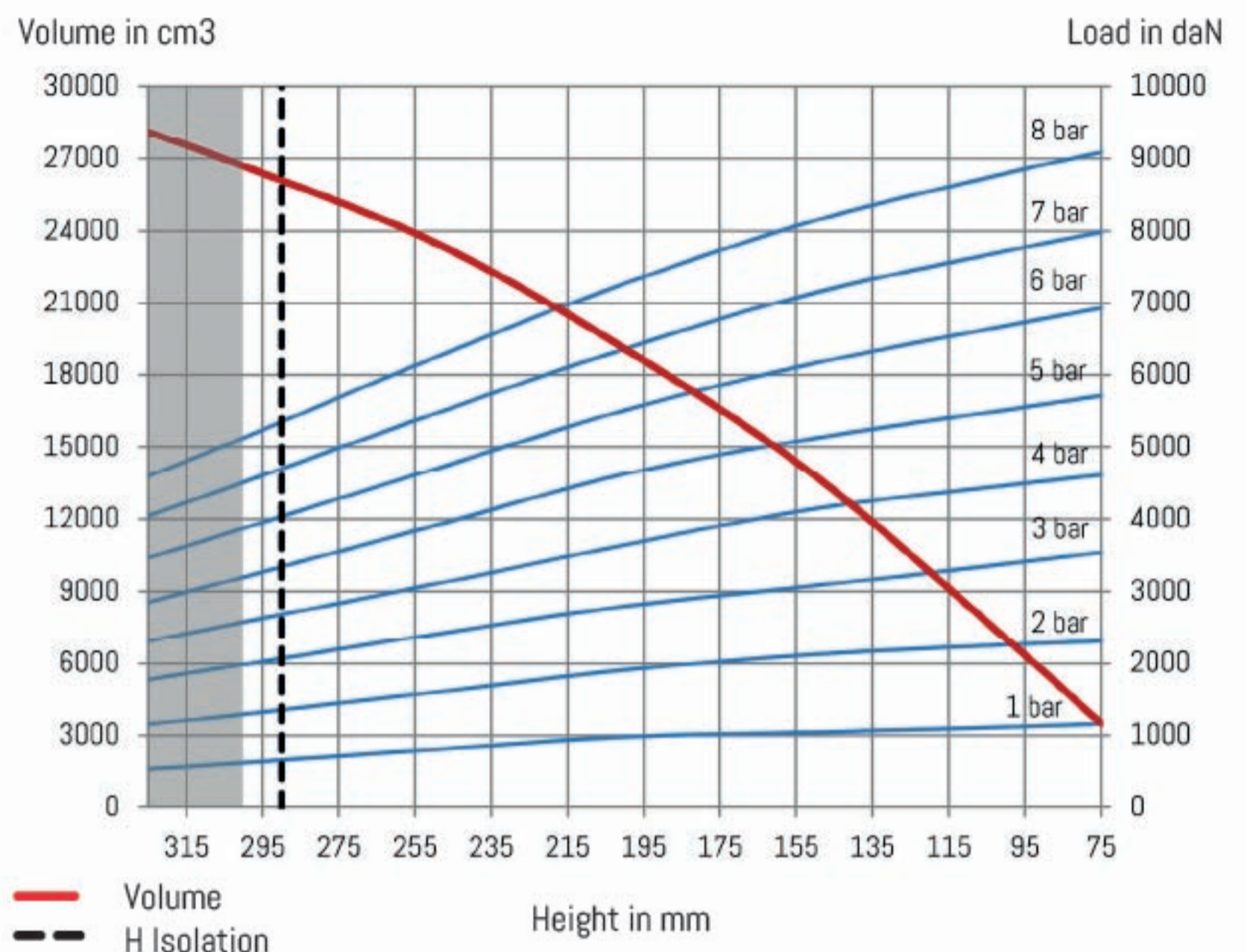

Temperatures

Standard	-40°C (-50°C static)	+70°C (+90°C static)
----------	----------------------	----------------------

References

DB16226	Bellow 2 convolutes 16" x 2 2 ply Stainless steel bolted air inlet G1/2 centered
---------	--

Characteristics in static condition (daN)

Height	2 bar	3 bar	4 bar	5 bar	6 bar	7 bar	8 bar	Vol 5 bar
75	2 306	3 539	4 614	5 714	6 925	7 984	9 090	3509
100	2 256	3 382	4 466	5 520	6 680	7 721	8 793	7039
150	2 125	3 080	4 146	5 127	6 164	7 147	8 145	13798
200	1 906	2 795	3 644	4 626	5 515	6 363	7 273	19094
250	1 598	2 405	3 100	3 908	4 695	5 464	6 237	23535
290	1 383	2 076	2 702	3 378	4 070	4 743	5 398	26229
300	1 298	1 984	2 575	3 201	3 874	4 512	5 133	26684
325	1 156	1 774	2 311	2 852	3 465	4 047	4 596	28120

Mounting instructions

Fastening torque M10 x 1,5 : 20 to 28 Nm

Indicative value of force to reach the minimum height at atmospheric pressure is 8 daN.